

Is steam power in your future?

By Skip Goebel

If you're thinking steam is old-fashioned, consider this: Almost a century ago, steam cars and ships attained speeds and efficiencies which are still difficult to attain, even with today's modern internal combustion engines.

Steam is one of the most powerful and the most dangerous forms of independent energy. It is so powerful that here at Tiny Power, makers of steam engines, at least once a week we get a call from someone who is going to save the world with steam. Usually, it takes only a few minutes of conversation to reveal that the caller needs more education in the basics of steam engineering.

This article is an attempt to answer some of the many questions people have about steam. And I guess the first question is: can it save the world, at least as far as your personal energy needs are concerned? That depends.

For the initial investment in this most labor intensive form of home power, you could probably buy a diesel generator and 5-10 thousand gallons of fuel with no significant changes in your lifestyle. If you plan to burn wood, you should know that it is a very established science to gasify wood and burn it in an internal combustion engine. This may be a more practical application for you.

If you have a need for large quantities of controllable heat, say to heat a large home, chicken house, or even a

kiln, steam plants excel in that the waste heat (exhaust) of a steam engine will give you excessive amounts of BTUs to play with.

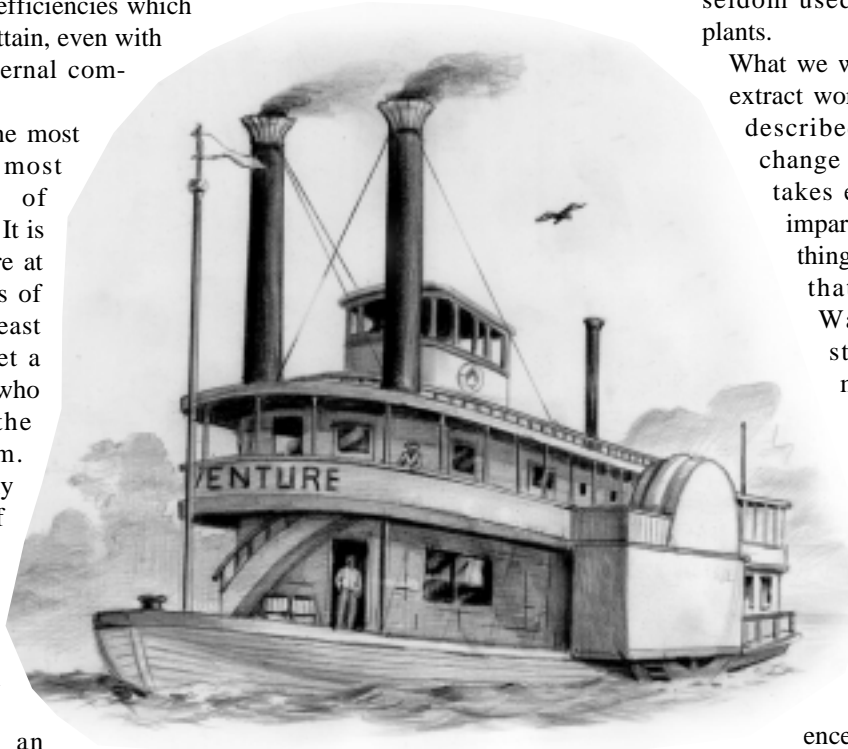

What is steam?

What is steam? "Water gone crazy with the heat" is as good an answer as any. Water will actually turn into steam in a vacuum if its temperature maintains 40 degrees F. Conversely, at a pressure of 3200 lbs. per square inch, and a temperature around 720 degrees, steam becomes "supercritical" and actually has a density the same as water. Modern steam systems run at these pressures because steam, which is a 'super-radiant' gas, absorbs and gives up heat much faster than water.

Only "dry" steam produces usable work. Steam is a dry, clear, tasteless gas. The cloudy stuff you can see

coming out of a kettle is actually just water vapor and has no use for our needs because if you can see it, all the work has gone out of it.

Once water is turned to steam, you can raise the temperature of the gas and store more energy/work in it. We call this "superheated" steam and though it is a desirable condition, it is seldom used in small-scale steam plants.

What we want to do with steam is extract work from it. Work is best described as the movement or change of velocity of mass. It takes energy to do work. To impart energy to a mass is one thing, and to transmit and use that energy is another.

Water, in the form of steam, is an excellent medium to transmit energy.

Water is a practical, safe and effective non-organic chemical that will readily absorb and transmit energy. To understand how this happens, try to think in differentials, i.e., differences in temperature, differences in pressure, or more specifically, differences in volume. As steam goes from one volume to another, work is done. An example of this is a piston going down in a cylinder creating more space or volume (expansion). As volumetric changes occur, temperature and pressure changes must also occur. These are laws of nature that you cannot change. We have units to measure the properties of mass. Generally, pressure is measured in pounds per square inch, volume in cubic feet, and temperature in degrees Fahrenheit. (I ain't metric yet, folks.)

At this point, let me introduce you to the British thermal unit (Btu). It's the United States unit of measure, which is similar to the metric system's calorie. It is nothing but a unit of heat. One Btu is the amount of heat

required to raise one pound of water one degree Fahrenheit. Conversely, if a pound of water drops one degree, it releases one Btu.

When any fuel is burned, it gives off energy in the form of heat, and that heat can be measured in either Btu's or calories. We'll use Btu's. An example is oak wood, which has 6-11 thousand Btu's per pound. Consider it as potential energy or energy waiting to happen. When oxidized (burned), it releases energy, and if we make steam with that energy, we can use the steam to transmit that energy somewhere else to do useful work.

Other sources of Btu's can be a hot spring or solar. Remember, what we are looking for is a difference in temperatures; the higher we can raise the temperature of water, the more work we can get out of the water. Unfortunately, the less the difference in temperature is, the greater the volume of water must be. For example, one pound of steam at 800 degrees has a certain amount of work in it; to produce the same amount of work at 400 degrees, you need a much greater amount of water.

So, we take one pound of water from 60 to 212 degrees and it takes 152 Btu's. ($212 - 60 = 152$) Now we add one more Btu and it all turns to steam at atmospheric pressure. Right? Wrong!

Raising water temperature is easy; changing water to steam is a whole 'nother ballgame. It takes a lot of energy to change the physical state of matter. Remember, it is not wasted here; rather it is stored.

To convert one pound of water from 212 degrees water to 212 degree steam (still one pound by weight) at atmospheric pressure takes another 970 Btu's. If we contain all of this, as in a boiler, we get a pressure differential (inside vs. outside). That pound of water, at 212 degrees, had occupied only .2 cubic feet. The steam at 212 degrees and at atmospheric pressure (or 14.7 lbs. per square inch) will occupy 27 cubic feet.

Now, if that steam isn't allowed to expand into those volumes because it is contained, we get an increase in pressure. It is this pressure that we will use to do our work.

What type of boiler?

The container in which we will make our steam is called a boiler. There are basically three types of boilers.

The Fire Tube boiler. This is the oldest, simplest, and the one that creates the steadiest production of steam. It is also the most dangerous (tends to blow up). Therefore, no more on this one. Forget it, nada, noway, etc. Paste this sticker on your brain: *There is a stick of dynamite in a gallon of water.*

The Water Tube. This is more efficient, safer, common, easy to build, etc. Basically, the design incorporates a series of tubes that stem downward from a drum and surround the combustion chamber (firebox). Steam is then drawn off the top of the drum where it is routed to its intended use by a pipe. (See figure 1.)

A common example of these types is a home heating boiler. Big ships and power plants use these designs as

well. We have one in our 23' steamboat that burns wood, and it works rather well. Let me interject here that if you burn solid fuel (wood or coal), *you will attend your boiler at all times.* If you can't, just drop the whole idea. If you can, be prepared for perpetual bliss.

The basic layout is as illustrated in the figure. Do not, by any means, use this illustration to design your own boiler. If you had to educate yourself by reading this article, you cannot, will not, and shall not build one of these. Remember, death is final (and painful).

There are countless plans available that are approved, certified, and well tested. Steam is definitely a 'finalized' science. If you look in the yellow pages, you will find certified boiler-makers who will do the job right. Technically, you are breaking the law by building a non-certified boiler.

Monotube or flash boilers. This by far is the most efficient, lightest, and safest boiler. It is easy and inexpensive to construct. They work best on continuous, steady operation. However, with little reserve capacity, they are sensitive to fluctuations in fuel and water supplies, not to mention loads. The most common versions

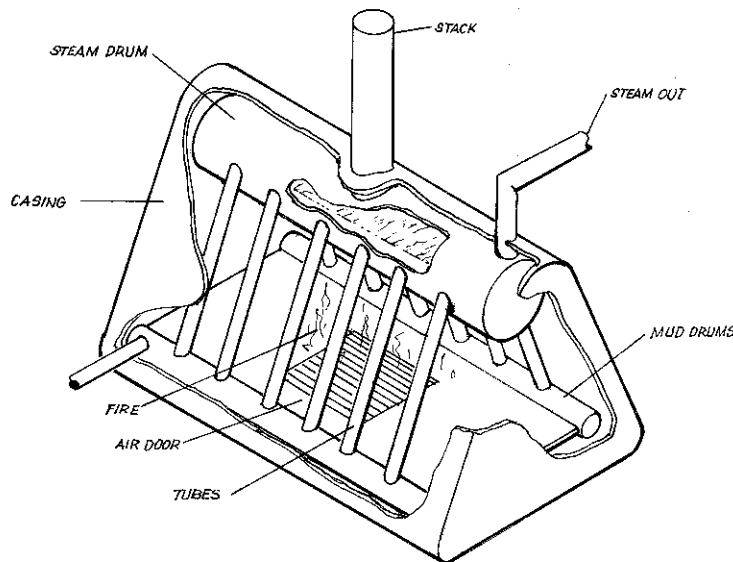
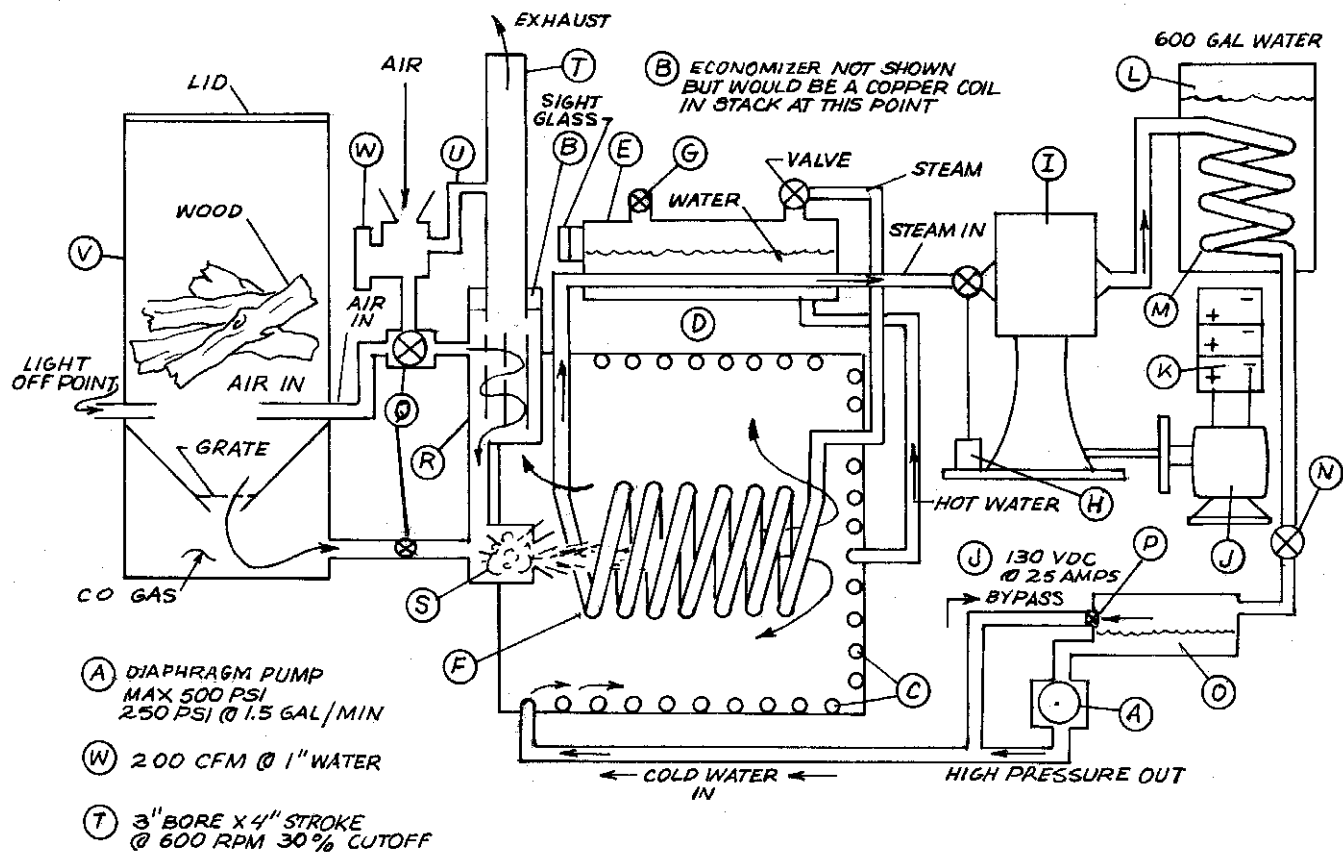

Figure 1. Water tube boiler



- A. Feed pump (pumps water to boiler)
- B. Economizer (picks up initial heat)
- C. Outer coil (brings water to steam temperature)
- D. Desuperheater (exchanges heat from superheater to the water)
- E. Separator (space for water and steam to separate)
- F. Inner coil or superheater (where steam will pick up massive Btu's)
- G. Safety valve (set to release excessive steam pressure. Very Important!)
- H. Governor (valve that regulates speed of engine)

- I. Engine (where steam does its work)
- J. Generator (turned by the engine to make D.C. electricity)
- K. Batteries (store electricity)
- L. Water tank—600 gallons (provides hot water for home and stores around 500,000 Btu's)
- M. Condenser coil (where exhaust steam will give up heat and condense back to water)
- N. Vacuum pump (pumps condensed steam or water back to hotwell—optional)
- O. Hotwell (holds a given amount of water to be pumped to boiler)
- P. Float valve—regulator (bypasses excessive water being pumped and regulates system)

- Q. Pressure activated draft (controls amount of fire)
- R. Air heater (preheats combustion air)
- S. Combustion chamber or burner (where fuel/air mixture is burned)
- T. Exhaust stack (spent gases are expelled here)
- U. Exhaust gas recirculation (provides flame control)
- V. Carbon monoxide generator (gasifies wood through destructive distillation)
- W. Air pump (forces air through system via carbon monoxide generator and burner)

Figure 2

are portable steam cleaners. Modern motels use a variation as water heaters.

Basically, they consist of one continuous coil of tubing or pipe in various configurations. Hence the name "Monotube." If we can provide exacting control of our fuel/water supply, then we have the ideal home-power boiler. Gas and liquid type fuels are the ideal type of fuel for monotubes because they are easy to regulate. And yes, there are approved designs out there for monotubes, and a professional can build them rather cheaply.

Combustion facts

A given amount of fuel needs a given amount of air to burn—no more and no less. It also needs the right amount of space to burn. Not enough air and you get incomplete combustion. Too much air and you're heating air.

Also, if we make the air meet the fuel too quickly, we get too hot a flame. That's bad because at temperatures over 1800 degrees, the nitrogen in air and some other chemicals start to oxidize. Not only is that poisonous, but it is wasted energy.

Combustion space is important because too little and we snuff the flame. Hold a lit candle so the flame touches an ice cube and if you look real close, there is an invisible layer of gas insulating the flame from the surface. That layer is unburned gases like carbon monoxide and is caused because the surface temperature was below the ignition temperature of the burnable gases. The rule is: Flame shall not touch metal.

Also, too much space and we can lose our coefficients of radiation. Generally speaking, a boiler gets 60-70% of energy transfer from radi-

ant energy, rather than hot gases.

The idea here is to gently unite air and fuel together and give it plenty of space or time to do its thing. There are set formulas for all of these factors, and your boiler builder will know what to do once you tell him what your needs are.

Enormous torque

Now that we have our steam, let's use it. We extract the work from steam by allowing it to expand in a controlled environment such as with a piston in a cylinder or a nozzle in a turbine.

Turbines are nice, and I have one myself, but in home scale sizes, they are very inefficient. It's just a matter of physics and costs. I know there are plenty of folks out there that will argue this point, but if they can come up with an efficient, home-scale turbine and sell it at a reasonable cost, I'll buy it.



Steam launch Santa Cruz II, Echo Lake, California

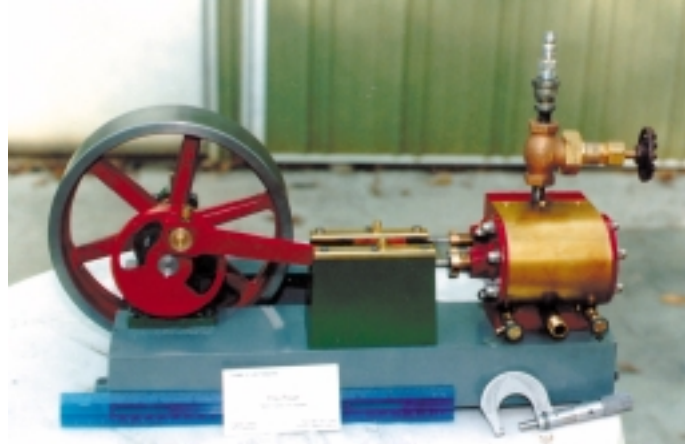

One of the small, high-quality steam engines made by the author's company, Tiny Power, Inc.

So, we're stuck with the piston (reciprocating) engine. Take heart. They work, they last, and they've been around for a long time. Steam engines are quiet, heavy, long lasting, and if modern, easy to maintain (our larger models use sealed ball bearings).

You can find plenty of used engines at old shipyards, refineries, ancient factories, mines, and railroads. Or you can buy a new one.

Consider steam engines akin to a fast acting hydraulic cylinder with an automatic valve. The ram is connected to a crank which turns and gives useful work. It is important to note that most steam engines are designed to take steam on both sides of the piston, which makes it a "single-stroke" engine. That also makes piston

engines produce enormous torque at almost any rpm. You can figure this torque by taking the square inches of the piston, multiplying that by the average cylinder pressure, and multiplying that figure by the length of the stroke measured in feet divided by 2. An example would be: A single cylinder engine has a bore of 3 inches and a stroke of 4 inches and runs at 100 lbs of average cylinder or "mean" pressure. A three-inch piston has



A bigger steamboat

approximately 7 square inches ($3 \times 3 \times .7854$) and a stroke of .33 feet. ($4/12$). $7 \times .33 = 2.31$. Times that by 100 pounds pressure $\times 2.31 = 231$ and divide that by 2, and you get 115.5 foot-pounds of torque. In reality, however, there are friction and efficiency losses.

Efficiencies are measured by how much steam/water an engine consumes to do a given amount of work. This is usually measured in pounds of steam/water per horsepower hour. In English, that means that for every horsepower produced for one hour, a certain amount of steam/water will pass through the engine.

Our shop unit has been in use for the last 18 years producing 4000 watts an hour. It consumes about 250 pounds of water (that has been turned to steam) in one hour. 750 watts is considered one horsepower, and when you figure efficiency losses, that works out to about 47 pounds per horsepower hour (250 lbs divided by roughly 5.3 horsepower). Put another way, for every horsepower the engine produced, we evaporated 47 pounds of water to steam and passed it through the engine.

There are engines that are much more efficient, but they cost a lot more than you want to pay. Efficiency is nice, but if the fuel is free, why should you care? Because the less wood you burn, the less you have to cut. I've used as much as a cord of wood in 10 days, and for me that's too much work.

All that brings us back to the question of why steam vs. other forms of independent energy? Because, if you have a use for large quantities of heat, the exhaust from the engine will give you just that.

Steam engines and boilers are usually most efficient at full settings, all valves open, full fire, etc... so that brings us to the next subject:

AC vs. DC

In a home setting, electricity is the most common form of energy. Therefore, a steam engine/generator proves to be the most practical application.

Generators are either A.C. or D.C. and both have their applications. At Tiny Power's shop, our 4kw Winco is A.C. Unfortunately, A.C. requires precise speed controls in the form of a delicate governor and heavy flywheel. I would suggest that most folks should use D.C. instead. D.C. is easier to make, control, and most importantly, you can store it. By making D.C. electricity and storing it, the steam system can run at max capacity for a short period (most efficient) rather than idle along all day (inefficient). It is practical because you can make your electricity early, then get on about your business.

I ran a 1kw D.C. steam power plant as a tourist attraction here in Branson, Missouri, for a time and fell in love with high voltage D.C. The system ran lights and motors at 120 volts. The only drawback is D.C. is hard on contacts and switches. You have to buy those expensive switches and breakers that are rated for D.C.

Steam for home power

Tiny Power has 13 different models of

engines plus accessories, and we cater mostly to hobbyists such as retired machinists and steamboaters worldwide. However, our heart still yearns towards self-sufficiency.

I myself am in the process of starting another company devoted to steam as a home power. I won't put it on the market until the system is foolproof, efficient, and affordable.

The following design will show a practical concept of a home-scale steam generator system. It is not an actual blueprint and I assume no liability for anyone who uses it as such. For those folks who think they are going to use their woodstove to make steam, please do the following: put me in your will, send the kids to live with grandma, give fair warning to the neighbors, and pay off your ocean-front property in Arizona.

Let us start with needs. Our home will need 2400 watt/hours of electricity per day. Since we only get 75% from a battery of what we put into it, we need to put in 3200 watt/hours ($2400 / .75 = 3200$). Even though 750 watts = 1 horsepower, there are inefficiencies in generators, belts, etc. A safe figure is a 30% loss, so 3200 watts over 70% efficiency = 4266 watts ($3200 / .70 = 4571$). Round up to 4600. Our horsepower requirement then is 4600 watt/hours divided by 750, which is 6.1 horsepower ($4600 / 750 = 6.1$).

Using 47 lbs of steam per horsepower hour to be consumed by our engine,



One-half-scale steam tractor

we take the 6.1 and multiply it by 47 and we get 286.7 or basically 287 pounds of steam/water is required.

We'll say that 1200 Btu's per pound of water/steam will be required to turn the water to steam at our working pressure of 120 psi. So, 287 pounds of steam/water x 1200 Btu's = 344,400 Btu's are required (287 x 1200).

Our boiler is 70% efficient, so 344,400 Btu's divided by 70% gives us the figure of 492,000 Btu's actually required (344,400 / .70 = 492,000).

Our wood contains a heat value of 7,000 Btu's per pound, so we need 70.3 pounds of wood (492,000 / 7,000 = 70.3). Let's spread the load over two hours, and we can see that we will burn 35.2 pounds of wood an hour (70.3 / 2 = 35.2), or about 35 pounds. To put that in perspective, that is a hefty armload of wood.

Remember, these are "real world" figures and are dramatically different from what some pink-hands so-called "educated" type will come up with.

If you follow the illustration in Figure 2, notice the direction of flow of fuel and water. This is a monotube design and will use electric pumps and blowers, giving easy control.

It will burn wood gas from "digesters" which heat the wood to ignition temperature but starve it for oxygen. This unburned gas is then mixed with heated air and burned at the base of the boiler. The combustion gases pass over the tubes of water and then over the air heater and on out the exhaust stack.

The water will enter the outside coil, pick up heat, go into the heat exchanger (desuperheater) and into the separator. Steam will exit the top of the separator and into the inner coil which acts as a superheater. The excessively hot steam will pass through the desuperheater, releasing some Btu's into the incoming water. The now "tem-



This steamboat, with its typical power plant, was used in the movie Maverick.

pered" steam will head towards the engine, where it will do its work. The engine exhaust will travel into a coil which is inside the large tank and release its remaining heat into the water. Having done that, our steam will have condensed into water and is forced through a vacuum pump which exhausts into the "hotwell." From this point, it is pumped back to the boiler via a high pressure feed pump to start all over again.

Getting educated

I can't emphasize enough the importance of getting educated before you tinker. Large sawmills usually have a power plant, and engineers are congenial folks who always want to show off their "baby." Tour old ships or refineries, and don't be afraid to ask questions. You'll get more from somebody if you ask questions than if you try to tell them what you know.

The ultimate education is to attend a steam club show. There are literally thousands every year. Chances are you are less than an hour's drive from one. Make sure you bring the kids. The shows are definitely a family affair. Any hobby shop should be able to tell you where one is in the area.

Also, check out the various publications available. There are several magazines about steam engines. All have a large classified ad section. We strongly recommend one called *The Steam*

Show Directory listing over 500 steam shows in this country and Canada.

Welcome to the fraternity.

For further reading

Live Steam

P.O. Box 629

Traverse City, MI 49685

(Steam engines of all kinds, on the Web, too)

Model Engineer

4314 W. 238th St.

Torrance, CA 90505

(Premier model making magazine, covers toy steam engines too)

Modeltec

P.O. Box 1226

St. Cloud, MN 56302

(All kinds of working models—steam, gas engines, hot air, etc.)

Steamboating

Rt. 1, Box 262

Middlebourne, WV 26149

(For the steamboat connoisseur, all sizes, great reading!)

Iron Men Album

P.O. Box 328

Lancaster, PA 17608

(Old steam tractors and stationary engines, large classifieds)

Engineers & Engines

1118 N. Raynor Ave.

Joliet, IL 60435

(Loaded with old engines and machinery, large classifieds)

Steam & Gas Show Directory

P.O. Box 328

Lancaster, PA 17603

(Lists all shows in Canada and U.S. This is a 'must have')

(Skip Goebel is chief engineer and part-owner of *Tiny Power, Inc.*, which manufactures steam engines. You can buy their 50-page catalog for \$5, or their 90-minute videotape for \$10 by contacting them at P.O. Box 1605, Branson, MO 65616. Tel.: (417) 334-2655.) Δ