

PROJECT BRIEF

Hybrid Village Power Systems in Amazonia, Brazil

by Roger Taylor 12/97

The Amazon region in Brazil is sparsely populated, with 17 million people living in five million km². This translates to less than 12% of the country's population living in 58% of its total area. Electricity generation in the region, where it exists, comes mainly from isolated diesel systems with capacities that range from a few kilowatts in small villages to tens of megawatts in some capital cities. While only 9% of Brazil's electric energy is consumed in Amazonia, consumption in the region has increased at a rate of approximately 18% per year over the last 20 years, greatly outpacing the national rate of 8.2%-growth for the same period. More than 300 minigridd systems are operated by local utilities in the Amazon Basin, and thousands more are privately owned. Still, more than 30% of the population lives without electricity. The table below shows the distribution of system capacity for the 300 utility-operated systems.

Distribution of Utility Diesel Systems, by Size.

System Size (kW)	% of Total # of Systems
0-100	10
100-500	37
500-1000	23
>1000	30
Total	100

The cost of remote electricity is high and is largely dependent on system size. In villages with diesel systems smaller than 100 kW, the cost can be greater than \$0.50/kWh and the systems operate for only 6 to 12 hours per day. The high electricity costs and limited availability are due primarily to system operation and maintenance problems, low capacity with high demand, and high fuel costs. The small systems are normally very unreliable. High electric costs are not borne by villagers, however, due to fixed electric tariff rates mandated by the government. Electric service, when provided, must be subsidized. The U.S. Department of Energy and the National Renewable Energy Laboratory are working with Brazilian utility providers to bring renewable wind and photovoltaic electricity into Brazil's energy mix.

Two differently configured hybrid electricity systems are being installed at two separate locations in the Amazon Basin. In Campinas, a hybrid system will meet nearly the entire load requirement with photovoltaic (PV)-generated electricity. In Joanes, the hybrid system will operate in a peak-sharing mode, transferring the peak demand of the village to off-peak periods at the diesel generation plant. In this way, it will use the maximum energy available from renewable sources. Renewable generation in Joanes is expected to reach 115 MWh/year, supplying 45% of the total current demand. A concurrent energy conservation program in the village is expected to boost that percentage to more than 60%.

Joanes

The village of Joanes is in the municipality of Salvaterra, on Marajó Island, in the state of Pará. New World Village Power Company of Vermont supplied the system design and the control and power-processor hardware of the 50-kW PV-wind-battery hybrid system installed at Joanes. The system will operate primarily in a grid-interconnected mode. It will deliver renewable energy directly to the grid or charge the battery bank to dispatch its full 50-kW capacity to the grid during times of peak demand.

One year of solar radiation (global horizontal, direct normal, and diffuse), ambient temperature, and wind (speed and direction) data is available for the site. During May 1994 to April 1995 the average wind speed was 6.58 m/s, and the daily average global-horizontal radiation was 5.30 kWh/m², indicating a good match of resource availability to the demand during a typical day.

The ratio of diffuse to global radiation ranged from 0.26 in July 1994, to 0.63 in February 1995, whereas the clearness index ranged from 0.40 in April 1995 to 0.60 in September 1994. The average temperature was approximately 27°C.

The Joanes system design and configuration are based on a rotary converter (shaft-coupled DC motor and synchronous alternator), for power conversion. It comprises four 10-kW wind machines supplied by Bergy Windpower and 10 kW of PV modules from Siemens Solar Industries. Below, a system schematic shows the connection to the Salvaterra grid.

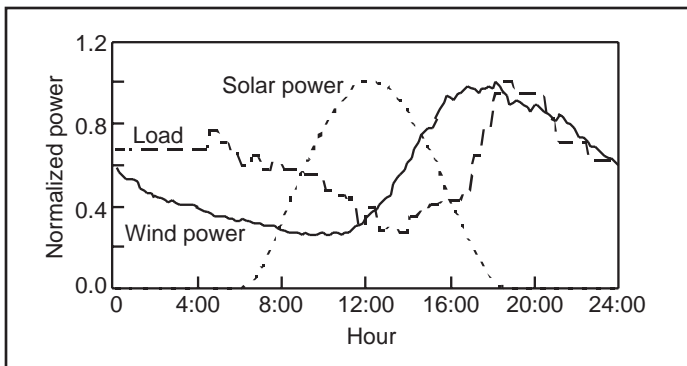

Daily load and power generation profiles, village of Joanes—annual daily average (1994/1995).

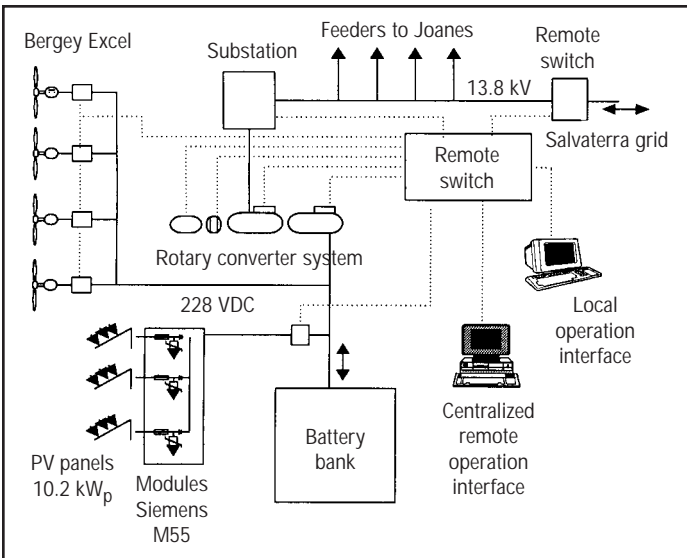

Simplified schematic drawing of Joanes hybrid system.

The Salvaterra power plant is one of 41 utility owned and operated diesel systems presently installed in the state of Parç. The plant has a nominal capacity of 1.2 MVA. Joanes receives electricity from this system, through a 17-km line operated at 13.8 kV. The village has 170 consumers, plus public lights.

Campinas

The village of Campinas is about 100 km upstream from Manaus, in the state of Amazonas, between the Solimões and Rio Negro rivers. The system installed in Campinas is a 50-kW PV-diesel-battery hybrid. Advanced Energy Systems Ltd. (AES), as a subcontractor to Bergey Windpower Corporation, supplied system controls and the power processor for the Campinas plant. Solarex Corporation supplied a 50-kW PV array. Two existing diesel units, currently supplying the village load, are being modified to interface with this hardware.

The Campinas system design and configuration is shown below. The PV panels are fixed. The AES inverter primarily provides control, data acquisition, fault detection, and diagnostics. A local operator interface is connected to the inverter via a serial link.

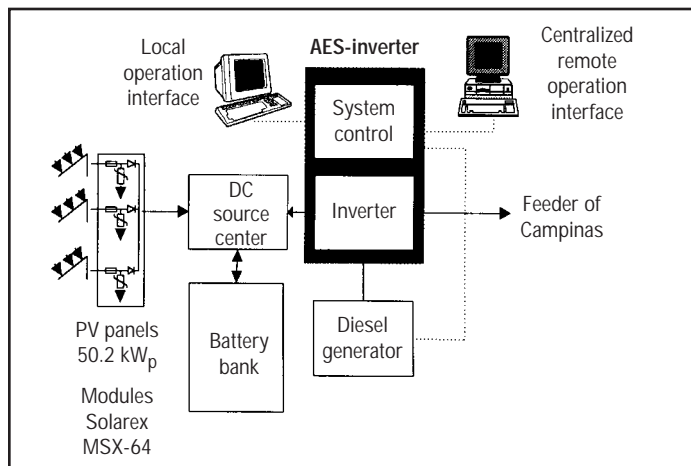

Simplified schematic of Campinas hybrid system.

These two hybrid systems represent significantly different approaches to the problem of remote power supply using renewable energy. Deployment of both systems is expected to provide the Brazilian utilities with installation and operating experience in hybrid power. Data gathered from these installations will contribute significantly to the body of knowledge about hybrid power systems and influence the design, implementation, and operating strategy of future projects.

NREL Contact

Web site: <http://www.rsvp.nrel.gov>

Roger Taylor
phone: (303) 384-7389
e-mail: roger_taylor@nrel.gov

Produced by the National Renewable Energy Laboratory, a U.S. Department of Energy national laboratory.

Printed with renewable source ink on paper containing at least 50% wastepaper, including 20% postconsumer waste.

NREL/FS-510-24192